

CHANNEL POURING FURNACE



Insulation:

1.
 - CERAMIC FIBRES behind bricks or CALDE® GUN MW STRONG LITE, secured by bricks or CALDE® GUN M 32

Hot face:

2.
 - CALDE® CAST UT 94 for iron and steel alloys
 - CALDE® CAST UB or CALDE® CAST LT 98 L as standard castable solution for iron alloys
 - CALDE® MIX BC 90 Z R or CALDE® MIX SA 68 S as DVM options
 - CALDE® CAST UB 75 S or CALDE® CAST LA 50 SZ for non-ferrous alloys

Inlet, outlet and slag door:

3.
 - CALDE® CAST UT 94 as standard castable solution

Cover:

4.
 - CALDE® CAST F 65 with CALDE® ANCHORING SYSTEM on top of CERAMIC FIBRES and CALDE® GUN MW STRONG LITE, secured by bricks or CALDE GUN M 32

Inductor:

5.
 - CALDE® MIX M S 86 BTI for iron alloys
 - CALDE® MIX SC 86 NTI for steel alloys
 - SILICA MIX B Cu 7 or CALDE® MIX BM 70 S for non-ferrous alloys

Repairs:

6.
 - CALDE® TROWEL SC 85 for all flange surfaces
 - CALDE® TROWEL HC 90 U or CALDE® TROWEL PC 85 U for non-ferrous alloys
 - CALDE® RAM PC 90 D or CALDE® RAM PB 89 for throat repairs

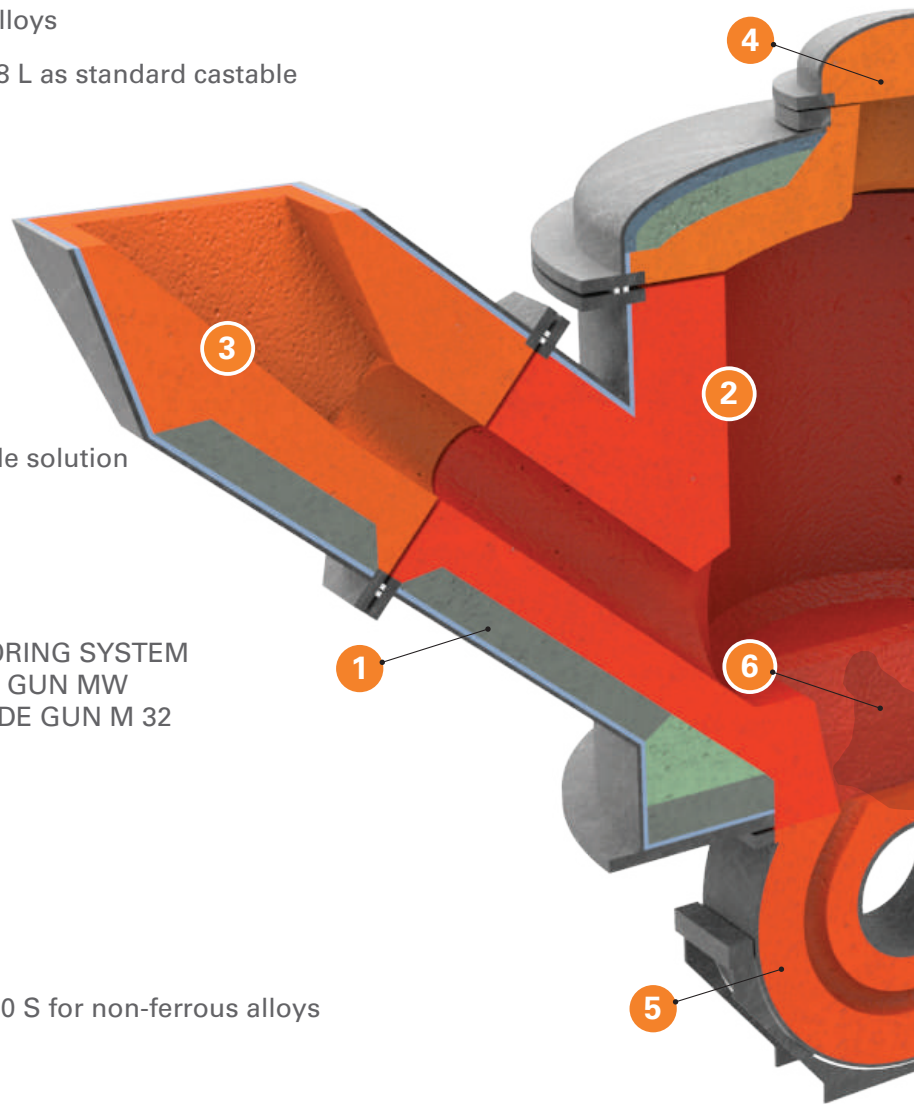

EQUIPMENT SPECIFICATIONS

PRODUCT NAME	Grain Size	Temp Limit	Yield (kg / dm ³)	Al ₂ O ₃	SiO ₂	SiC
CALDE® GUN MW STRONG LITE	4mm	1320	1.60	39	40	
CALDE® GUN M 32	3mm	1650	2.80	80	13	
CALDE® CAST UT 94	6mm	1800	3.15	93	6	
CALDE® CAST UB	6mm	1680	2.85	85	12	
CALDE® CAST LT 98 L	6mm	1850	3.15	98	0.2	
CALDE® MIX BC 90 Z R	6mm	1650	3.00	90	3	
CALDE® MIX SA 68 S	6mm	1670	2.60	67	29	2
CALDE® CAST UB 75 S	6mm	1650	2.75	77	11	8
CALDE® CAST LA 50 SZ	6mm	1650	2.70	50	28	10
CALDE® CAST UT 94	6mm	1800	3.15	93	6	
CALDE® CAST F 65	6mm	1460	2.30	64	30	
CALDE® MIX M S 86 BTI	5mm	1700	2.80	12	2	
CALDE® MIX SC 86 NTI	6mm	1700	3.00	86	1	
SILICA MIX B Cu 7	7mm	1580	2.24		90	7
CALDE® MIX BM 70 S	6mm	1600	2.50	68	22	5
CALDE® TROWEL SC 85	0.5mm	1600	2.70	86	9	
CALDE® TROWEL HC 90 U	3mm	1600		89	9	
CALDE® TROWEL PC 85 U	0.5mm	1650		86	10	
CALDE® RAM PC 90 D	6mm	1650	3.15	92	1	
CALDE® RAM PB 89	4mm	1700	2,90	81	11	

DISCLAIMER: CALDERYS does not warrant the accuracy, fitness for purpose or update of any information disclosed herein. The recipient shall refer to the present content as indicative only. For any instructions or advice, please address formal request to CALDERYS. This document and the information contained herein are the exclusive property of CALDERYS. Reproduction, alteration, copy, release, publication or distribution, in whole or in part, is not allowed. References, trademarks and specifications of the products may vary according to the geographical area to be supplied. For any inquiries regarding supply of products, please liaise with CALDERYS nearest sales area manager.